

A close-up, low-angle shot of a Hunter HVLS (High Volume, Low Speed) fan. The central motor housing is a brushed metal, cylindrical shape with a circular logo in the center that reads "Hunter INDUSTRIAL". Several long, white, curved blades are attached to the motor. The blades have a smooth, aerodynamic shape and are secured with screws. The background is dark, making the metallic and white components stand out. A vertical green bar is on the right side of the image, containing the text "Hunter HVLS" and "INSTALLATION MANUAL".

Hunter

HVLS

**INSTALLATION
MANUAL**

Contents



BEFORE YOU BEGIN

Safety & Precautions	3
Fan Placement	6
Tools Needed	8
In The Box	9
Pre-Installation Checklist	10
Adjustable Downrod	11



INSTALLATION

Step 1: Mounting	13
Step 2: Retention System	17
Step 3: Motor Assembly	18
Step 4: VFD Control Panel	19
Step 5: Guy Wires	20
Step 6: Blade Installation	22



REFERENCE

Electrical	24
Fan Network Configurations	27
Fire Panel	31
Line Filter	33
Maintenance	36
Troubleshooting	37

1886

LEGACY

The Hunter legacy is not only about quality—it's about longevity. We invented the ceiling fan. We build fans that last, fans that are designed as fans. We design our fans while considering each person in the process—from the installer to the owner.



AUTHENTICITY

In a world full of impersonators, be an original. We invented the ceiling fan, and we stand behind our products.

Hunter



BEFORE YOU BEGIN

SAFETY & PRECAUTIONS

Important Safety Information

To prevent SERIOUS INJURY, DEATH, and PROPERTY DAMAGE, you should read, understand, and follow the warnings and instructions in this manual before installing or operating the fan.



READ AND SAVE THESE INSTRUCTIONS. This manual must always be kept with the fan and should remain with the fan if it is transferred or sold. Always give manual to fan owner following installation.

WARNING



FIRE, ELECTRIC SHOCK AND CRUSH HAZARDS.

TO PREVENT SERIOUS INJURY OR DEATH:

- ALWAYS mount fan directly from building structure that can withstand double the maximum hanging fan weight and install the Retention Cable.
- BEFORE installing or servicing your fan, ALWAYS disconnect the power by turning off the circuit breaker or breakers to the fan locations. If you cannot lock the circuit breakers in the off position, securely fasten a prominent warning device, such as a tag, to the electrical panel.
- All wiring must be in accordance with national and local electrical codes, including ANSI/NFPA 70. If you are unfamiliar with wiring or are in doubt, consult a qualified electrician.
- DO NOT install fan to be used in the presences of flammable vapors and gasses or in environments where combustible dust is present.
- DO NOT bend the blades or blade holders when installing or cleaning the fan.
- DO NOT insert foreign objects in between rotating fan blades.

Installation, adjustment, repair, or maintenance must be performed by qualified personnel.

Follow all safety practices and instructions during the installation, operation, and servicing of the fan. Failure to apply these safety practices could result in death or serious injury. If you do not understand the instructions, please call our Technical Department at 1-844-593-FANS (3267) for guidance.

Always check federal, state, and local codes before installing fan.

Code compliance is the responsibility of the installer. Check all relevant codes to make sure that all product certifications, product listings, and building regulations are met.

Professional installation practice requires following local utility company guidelines for connecting to AC mains. This unit is for professional use only and is not required to comply with EN 61000-3-2:2006. This fan conforms to ANSI/UL standard 507, Electric Fans and is certified to CSA STD C22.2 No. 113, Fans & Ventilators.



CONFORMS TO UL STD 507 CERTIFIED TO CAN/CSA STD C22.2 NO. 113





BEFORE YOU BEGIN

SAFETY & PRECAUTIONS

WARNING **ELECTRIC SHOCK HAZARD**

TO PREVENT SERIOUS INJURY OR DEATH:

- **BEFORE** installing or servicing your fan, **ALWAYS** disconnect the power by turning off the circuit breaker or breakers, to the fan locations and confirm Lockout/Tagout procedures are in place. If you cannot lock the circuit breakers in the off position, securely fasten a prominent warning device, such as a tag, to the electrical panel.
- All wiring must be in accordance with national and local electrical codes, including ANSI/NFPA 70. If you are unfamiliar with wiring or in doubt, consult a qualified electrician.
- Do not use an extension cord with fan.
- Do not remove covers while power is on.
- Do not use improper voltage source.

All fan controls and incoming power should be installed only by qualified technicians familiar with the requirements of the National Electrical Code and local codes. Failure to follow these guidelines will void the manufacturer's warranty.

All electrical controls are configured at the factory and are ready to use. No user adjustments are available. Follow the included installation instructions when installing this device to ensure proper operation. Do not make any changes to any part of the fan without first consulting Hunter Industrial. Installation is to be in accordance with ANSI/NFPA 70: National Electrical Code and local codes.

The user is responsible for compliance with all international and National Electrical Code requirements with respect to grounding of all equipment. Many of the parts of this unit operate at line voltage.

Before installing, servicing, or cleaning the unit, switch power off at the service panel, lock the service disconnecting means, and confirm Lockout/Tagout procedures are in place to prevent power from being switched on accidentally. When the service disconnect means cannot be locked, securely fasten a prominent warning sign, such as a tag, to the service panel.

To reduce the risk of electric shock, serious injury, and death, only use this unit as intended by the manufacturer. If you have any questions, call our Technical Department at 1-844-593-FANS (3267).



CONFORMS TO UL STD 507 CERTIFIED TO CAN/CSA STD C22.2 NO. 113



BEFORE YOU BEGIN

SAFETY & PRECAUTIONS

WARNING **CRUSH HAZARD**

To prevent serious injury or death, **ALWAYS** attach the Retention Cable to the fan motor and secure to the building structure on **EVERY** fan.

The Retention Cable, if installed per Hunter Industrial specifications, can limit the distance the fan could fall in the unlikely event of mounting system failure. Failure to install and to secure the retention cable will void your warranty.

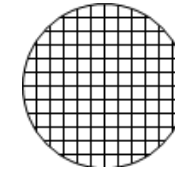

Mark the Floor to Alert Personnel

When mounting a fan in an area where materials could be elevated and contact the rotating fan blades, be sure to mark or rope off the area of install.

Weight and Torque Considerations

Always mount fan directly to building structure that can withstand approximately double (2x) the maximum hanging weight of the fan.

The maximum fan hanging weight and torque is as follows:

MAXIMUM	HANGING WEIGHT	TORQUE
24' Titan	212 lbs.	75 ft lbs.
24' ECO	150 lbs.	75 ft lbs.
14' XP	135 lbs.	75 ft lbs.

If there is any uncertainty about the potential for the building structure to withstand double the maximum hanging weight of the fan, a professional structural engineer should perform a thorough evaluation of the building prior to purchasing the fans. Hunter Industrial provides guidelines for mounting fans; however, it is the sole responsibility of the building owner and installer to ensure the safety of the mounting system and retention cable, the building structure is sound, and the installation complies with all federal, state, and local codes.

Always use Personal Protective Equipment

You should always wear Personal Protective Equipment, such as a Hard Hat, Safety Glasses, and a Fall Harness when installing industrial fans.

Damaged Equipment

Never operate or install any fans or fan accessories that appear to be damaged. Failure to follow this instruction can result in death, serious injury or equipment damage.

To reduce the risk of personal injury, do not bend the blades or blade holders when installing or cleaning the fan.

Do not insert foreign objects in between rotating fan blades.

Service

If the fan does not operate properly using the procedures in this manual, remove all power to the unit and contact our Technical Department for further assistance at 1-844-593-FANS (3267).



BEFORE YOU BEGIN

FAN PLACEMENT

ALWAYS MOUNT FAN SO THE BOTTOM EDGE OF BLADE TO THE FLOOR IS AT LEAST 10 FEET FROM THE FLOOR AND AT LEAST 25% OF FAN DIAMETER FROM THE CEILING.

A large fan, 20 to 24 foot in diameter, performs best at 20 to 30 feet above the floor, but acceptable performance has been demonstrated as low as 10 feet and as high as 50 ft.

Always mount fans away from the following:

Sprinkler Systems

Prior to installing fans, review all codes applicable to sprinkler systems and fans to ensure code compliance and refer to NFPA 13: Fire Sprinkler System Installation. In any installation where fire sprinklers are present, the fan should not interfere with their operation.

- Fans should be located at least 3 feet below a sprinkler deflector.
- Fans should be centered between 4 adjacent sprinklers.
- The Industrial Control Panel should be connected to a fire relay system, which can stop the fans in the event a fire occurs.

It is your responsibility that the installation complies with the applicable codes. For assistance, please call our Technical Department at 1-844-593-FANS (3267).

Walkways and Mezzanines

If the building has elevated walkways or mezzanines, mount the fans so that a person cannot reach the rotating blades in any way. Position fans so that the tips of the blades are at least 5 feet away from any area where a person may be able to extend outward to reach them.

Lights and Skylights

If possible, avoid mounting fans directly below lights or skylights to avoid any strobe effect caused by moving blades.

There should be a minimum of 2 feet between the blades and any light fixture.

Air Discharge Locations

Fans should not be located directly beneath any vertical air discharge. This includes air conditioning units and evaporative coolers. Such equipment can be used effectively in conjunction with high-volume, low-speed (HVLS) fans; however the discharge of the unit must be located outside the swept area and at a distance of at least two times the diameter of the fan. For horizontal air discharge, the fan cannot be placed in direct path at any distance.

Windy Locations

Do not operate or install fans in outdoors or in areas exposed to wind. Failure to follow this instruction can result in death, serious injury, or equipment damage.

Wet Locations

DO NOT locate fans where they may come into direct contact with water. These fans are only suitable for mounting in damp locations.

Other HVLS Fans

See the chart on the next page to determine proper spacing between adjacent fans.



BEFORE YOU BEGIN

FAN PLACEMENT

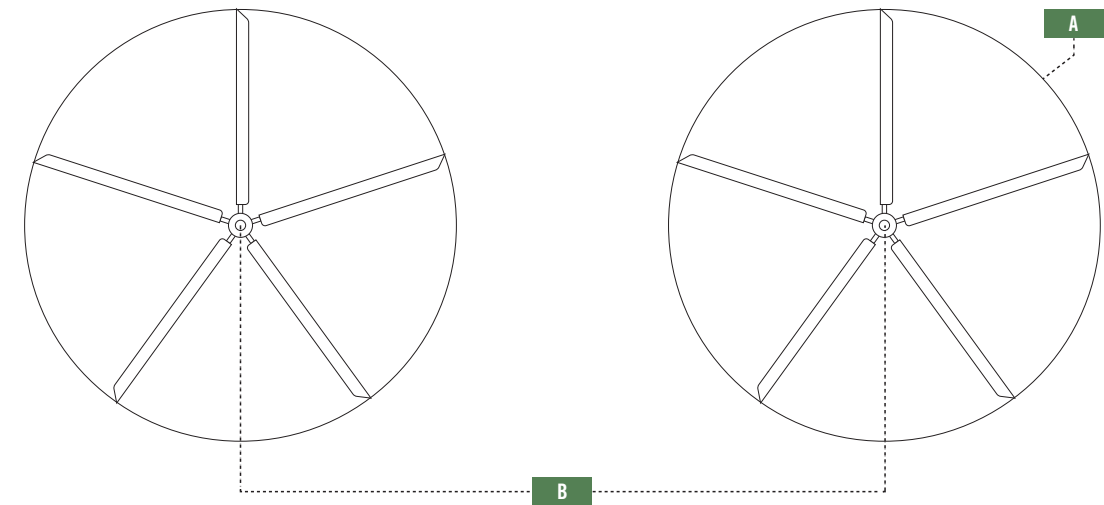

FAN PLACEMENT: FAN SPACING CHARTS

ECO	
A	B
DIA	MIN-MAX
24 ft	60ft - 96ft
20 ft	50ft - 80ft
18 ft	45ft - 72ft
16 ft	80ft - 64ft
14 ft	35ft - 56ft
12 ft	30ft - 48ft
10 ft	25ft - 40ft
8 ft	20ft - 32ft

TITAN	
A	B
DIA	MIN-MAX
24 ft	60ft - 120ft
20 ft	50ft - 100ft
18 ft	45ft - 90ft
16 ft	80ft - 40ft
14 ft	35ft - 70ft

XP/RM	
A	B
DIA	MIN-MAX
14 ft	35ft - 56ft
12 ft	30ft - 48ft
10 ft	25ft - 40ft
8 ft	20ft - 32ft
7 ft	18ft - 28ft

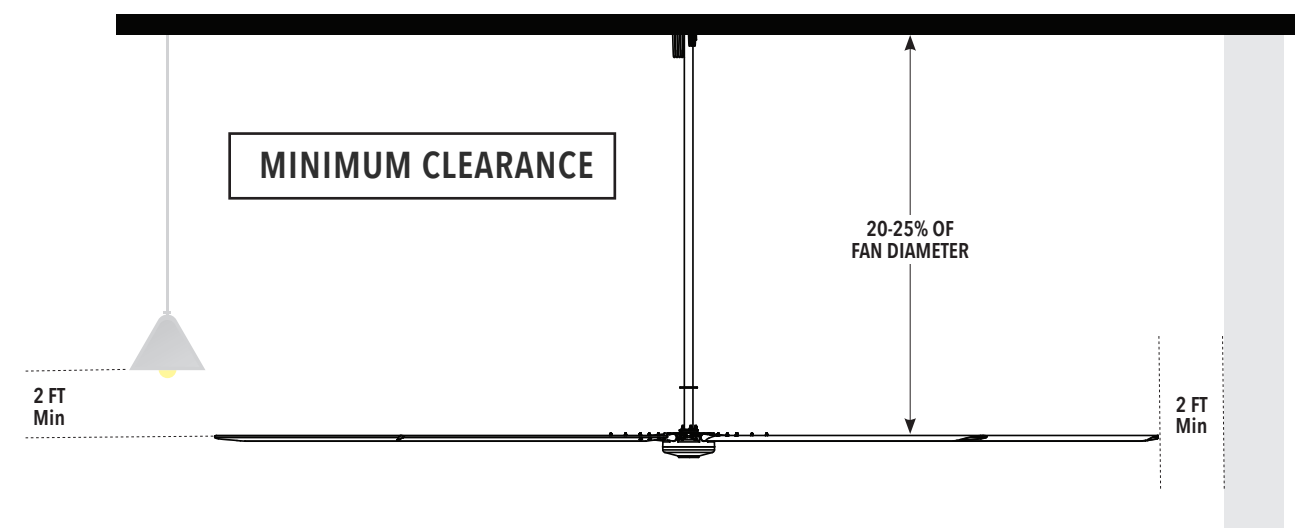



BEFORE YOU BEGIN

TOOLS NEEDED

<input type="checkbox"/>	Metric Combination Wrench Set (10mm - 19mm)
<input type="checkbox"/>	Metric (Deep & Short) Socket and Ratchet Set
<input type="checkbox"/>	Standard (Deep & Short) Socket and Ratchet Set
<input type="checkbox"/>	Metric Allen Wrench Set
<input type="checkbox"/>	Metric Allen Socket Set
<input type="checkbox"/>	Tape Measure
<input type="checkbox"/>	Magnetic Level (Magnetic post level recommended)
<input type="checkbox"/>	Torque Wrench
<input type="checkbox"/>	Wire Rope Cutters (optional)
<input type="checkbox"/>	Phillips and Flat Head Screwdrivers
<input type="checkbox"/>	#10 to #14 AWG Strippers (optional)
<input type="checkbox"/>	Multimeter (optional)
<input type="checkbox"/>	Cat5 Termination Tools (optional)
<input type="checkbox"/>	Cat5 Tester (recommended)
<input type="checkbox"/>	15mm Socket
<input type="checkbox"/>	6mm Hex Key (Allen) Wrench



BEFORE YOU BEGIN

IN THE BOX

FAN COMPONENTS



FAN COMPONENTS

- a) (1) Downrod
- b) (1) Motor & Motor Nuts¹
- c) (1) HMI Controller(s) (Sold Separately)²
- d) (1) VFD Control Panel
- e) Blades: Titan (5), ECO (4), XP (4)³

¹ ECO motor shown. Motor will vary dependent on HVLS fan being installed.

² 350 Series HMI shown. HMI will vary dependent on HMI being installed

³ ECO blades shown. Blade quantity will vary dependent on HVLS fan being installed.

MOUNTING HARDWARE KIT (EXCLUDING XP/RM)

- a) (2) Shims
- b) (2) Clamps
- c) (4) Bolts, Nuts, and Washers

GUY WIRE KIT (EXCLUDING XP/RM)

- a) (2) Gripple Kit
- b) (4) Beam Clamps
- c) (4) Turnbuckles

MOUNTING HARDWARE KIT

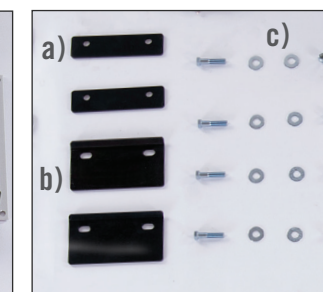

GUY WIRE KIT

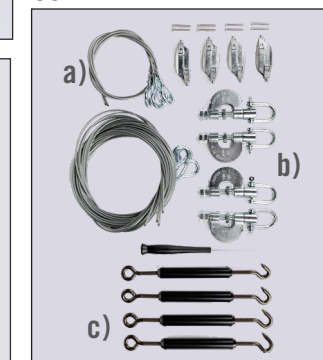

COMMUNICATION KIT



COMMUNICATION KIT

- a) 100ft Cat5 Cable (Terminated)

INSTALLATION MANUAL

- a) HVLS Installation Manual
- b) HMI installation and user guide

	TITAN	ECO	XP/RM
DOWNROD	1 Adjustable Downrod	1 Adjustable Downrod	1 Fixed Downrod
MOTOR	1 (Silver)	1 (Black)	1 (Black)
HMI CONTROLLER	>1	>1	>1
VFD CONTROL PANEL	1	1	1
BLADES	5	4	4
MOUNTING HARDWARE KIT	1	1	n/a
GUY WIRE KIT	1	1	n/a
COMMUNICATION KIT	1	1	1
INSTALLATION MANUAL	1	1	1



BEFORE YOU BEGIN

PRE-INSTALLATION CHECKLIST

<input type="checkbox"/>	A structural engineer has approved the mounting structure.
<input type="checkbox"/>	The location of the fan will allow for a minimum of two feet of blade clearance from any obstruction and at least 10 feet of clearance above the floor.
<input type="checkbox"/>	The fan location will not be subjected to high winds.
<input type="checkbox"/>	If installing multiple fans, reference the fan placement chart on page 7 for optimal spacing.
<input type="checkbox"/>	The control panel, motor and blade assemblies are all marked with the diameter. Ensure the markings all match when assembling the fan.
<input type="checkbox"/>	The control panel voltage markings should match your buildings supply power.
<input type="checkbox"/>	The fan power should be installed within 3 ft of the top of the downrod. <i>Please refer to the chart on page 24 for the appropriate receptacle and breaker size.</i>
<input type="checkbox"/>	Inspect product to ensure there are no visible damages or defects to fan(s) components (<i>Refer to page 9 for fan components list</i>).
<input type="checkbox"/>	Ensure fan components have not been disassembled or modified beyond the scope which Hunter offers in their product line.



BEFORE YOU BEGIN

ADJUSTABLE DOWNROD

THERE ARE THREE DIFFERENT ADJUSTABLE DOWNROD LENGTH CONFIGURATIONS:
 2.5 - 4 FT (0.77 - 1.22m) | 4.5 - 6 FT (1.38 - 1.83m) | 6.5 - 10 FT (1.99 - 3.05m)
 DOWNROD WILL SHIP PRE-WIRED AND FULLY ASSEMBLED IN THE SHORTEST CONFIGURATION.



TOOLS NEEDED

- 15mm socket
- 6mm hex key (Allen) wrench

Downrod Length adjustments may be made in increments of 6".



BEFORE YOU BEGIN

ADJUSTABLE DOWNROD

Adjusting Downrod Length

There are three different adjustable downrod length configurations: 2.5 - 4 FT (0.77 - 1.22m) | 4.5 - 6 FT (1.38 - 1.83m) | 6.5 - 10 FT (1.99 - 3.05m). Each configuration will be shipped from the factory in the shortest configuration but will have all necessary components for the longest configuration. If a longer length of downrod is necessary for the install, adjust the downrod at ground level before installing to the building structure.

How to Adjust the Downrod Length:

A

Remove the two adjustments bolts and hardware.

B

Slide the upper and lower tubes apart until the matching pair of adjustment holes line up to achieve desired length.

C

Replace the two adjustment bolts and hardware.

D

Torque the adjustment bolts, clockwise, to 53.8 ft-lbs., until bolts are tightly secured.

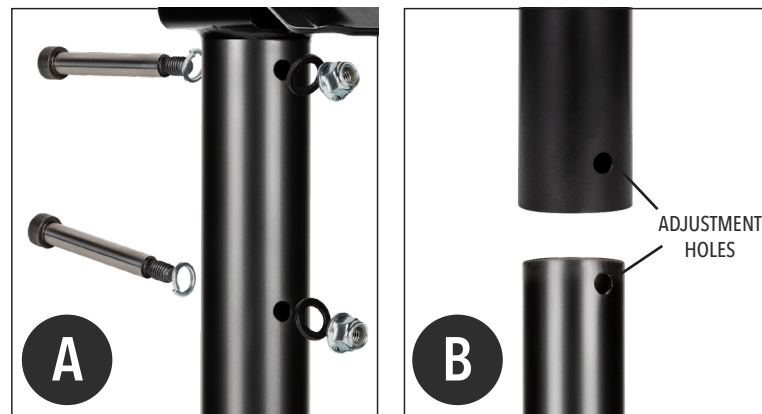

NOTE

Ensure that bolt is tightly secured to the downrod and that the washer did not get hung up on the end of the adjustment bolt, causing the bolt to be loose.

Do not install downrod with only one bolt or extend downrod beyond where both bolt holes of the inner and outer tubes line up. **Do not** extend past warning sticker.

Do not adjust downrod length while downrod is mounted or when the fan is attached to the downrod. Length adjustment should happen at the ground level.

Beware pinching the motor cable or safety cable while replacing adjustment bolts.

Mounting Adjustable Downrod: Follow mounting instructions starting on page 13.



INSTALLATION

STEP 1: MOUNTING

WARNING



CRUSH HAZARD. To prevent **SERIOUS INJURY** or **DEATH**, **ALWAYS** mount fan directly from building structure that can withstand double the installed fan weight.

ADJUSTABLE DOWNROD MOUNT OVERVIEW

A

Secure bracket and downrod to lift and raise to an I-Beam that is part of the building structure.

B

Assemble shims and clamps on one side of the bracket per the figure below.

Hook the clamp on one side of the I-beam and tighten hardware until the clamp and shim are snug but can still be moved.

C

Assemble the opposing shim and clamp on to the I-beam and Tighten using a 3/4" socket and wrench.

D

Center the mount under the I-beam. Check that clamps have maximum engagement on both sides and tighten hardware.

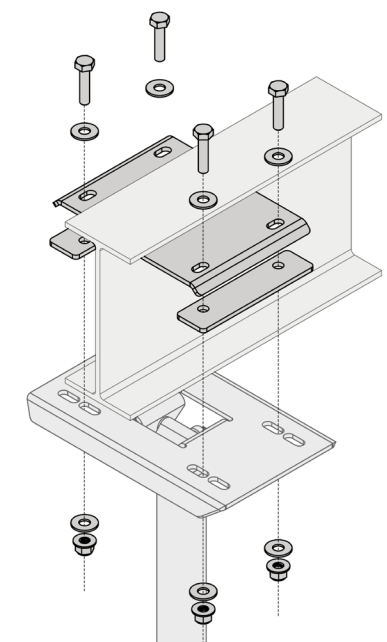
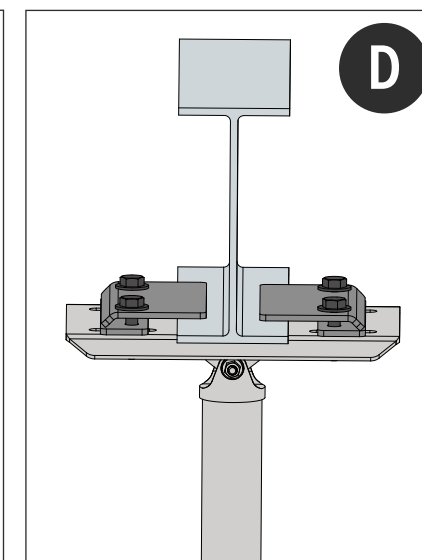
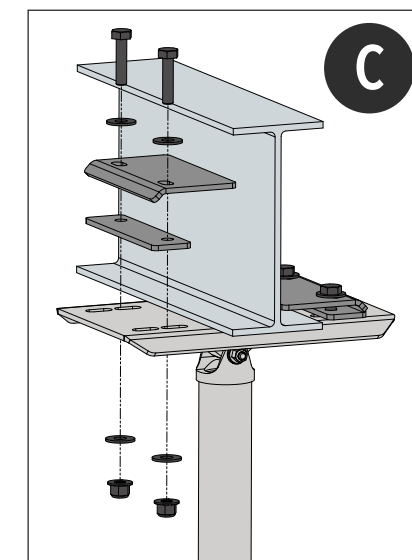
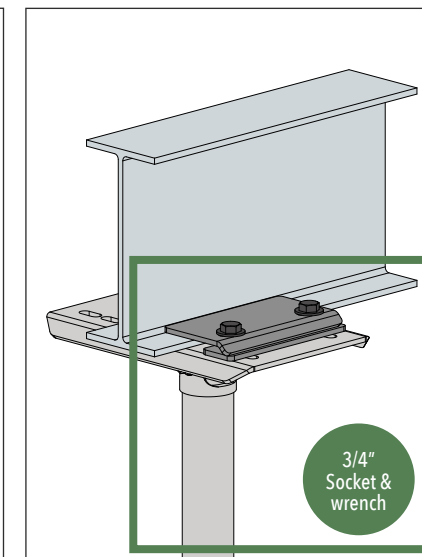
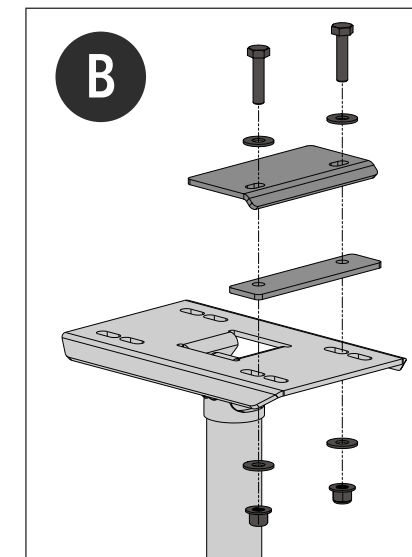

WARNING: SUPPORT DIRECTLY FROM BUILDING STRUCTURE



INSTALLATION

MOUNTING CONFIGURATION

CHANNEL HEIGHT	MATERIAL THICKNESS	MAXIMUM SPAN LENGTH
1 5/8"	12 GA	84'
1 5/8"	14 GA	72'
1 5/8"	16 GA	60'
1 3/8"	12 GA	60'
7/8"	12 GA	30'
3 1/4"	12 GA	240"
2 7/16'	12 GA	156"

K-BAR MOUNTING

Example of mounting to a truss with standard mount hardware.

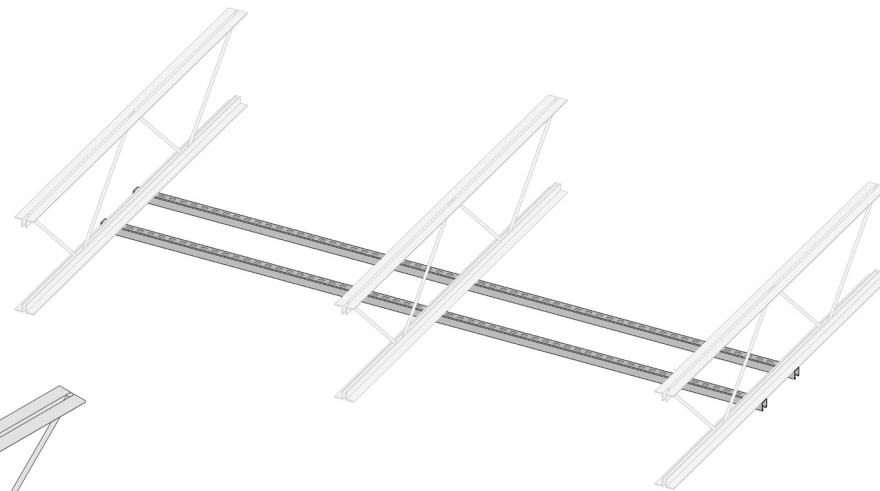
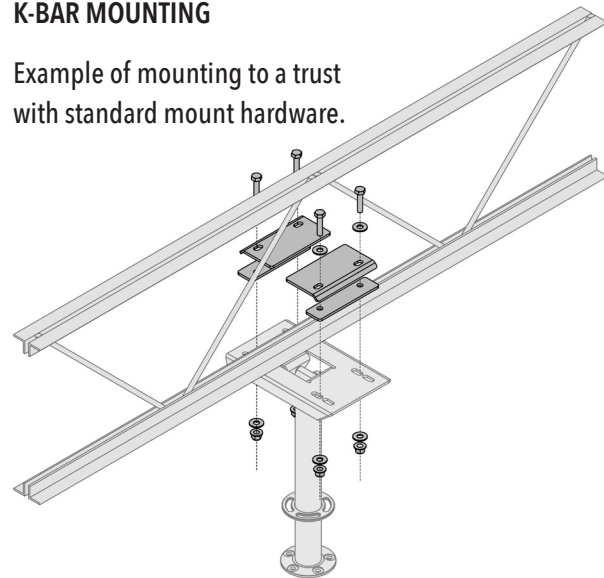

STRUT CHANNEL MOUNTING

If bracing is required unistrut can be used, we recommend spanning at least three trusses or perlin.

Fan	Standard Mounting Kit	Additional Mounting Options
Titan	I-Beam Standard Mounting Kit	K-Bar, Unistrut, Perlin, Glulam, Wood
Eco	I-Beam Standard Mounting Kit	K-Bar, Unistrut, Perlin, Glulam, Wood
XP	I-Beam Standard Mounting Kit	K-Bar, Unistrut, Perlin, Glulam, Wood

REMINDER

The retention cable should always be secured around the building structure or a beam, not around something bolted on, such as a strut channel.



INSTALLATION

STEP 1: MOUNTING

UNISTRUT MOUNTING

A

Select proper strut channel from the chart.

B

Use strut channel or similar to span three points of the building structure and create a stable attachment point for the fan.

C

Bolt fan mounting plate to attachment point using 1/2" grade 5 bolts and nylon locking nuts.

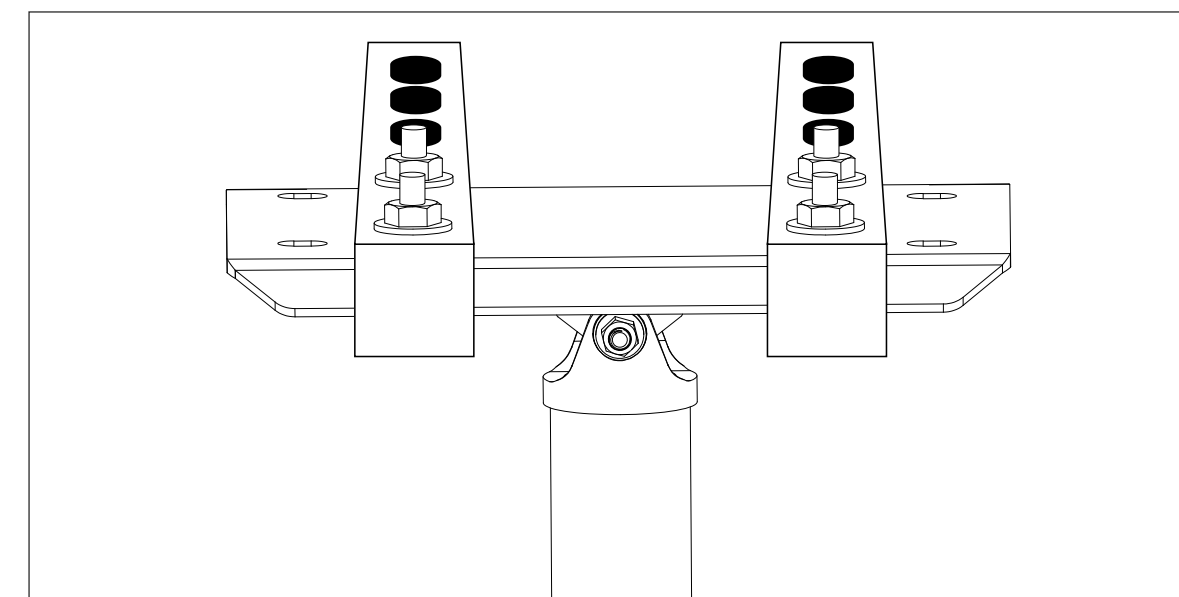
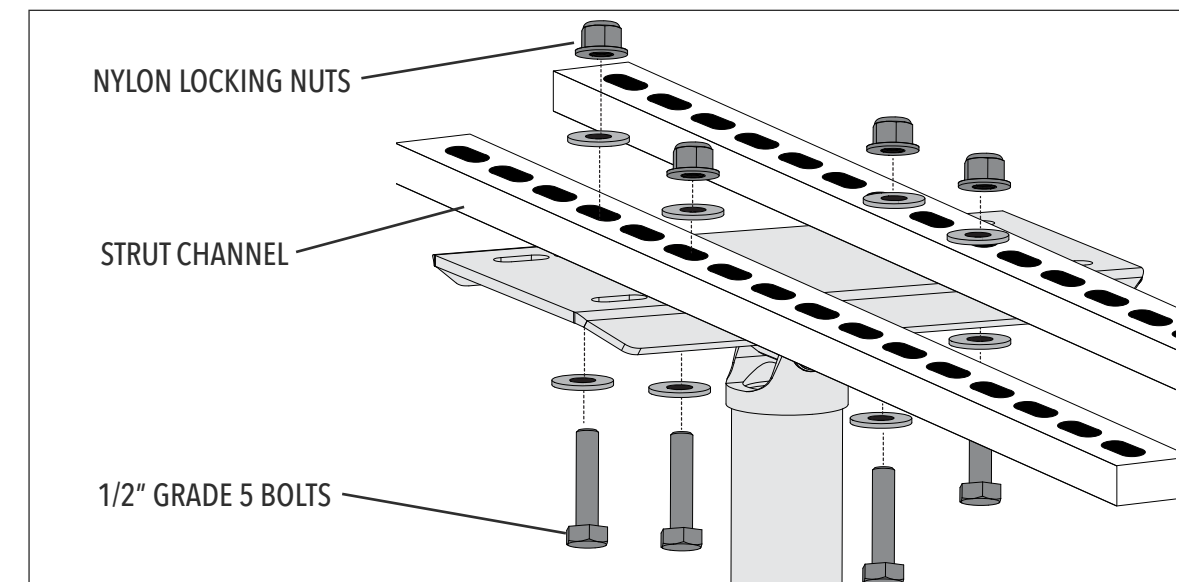

WARNING: SUPPORT DIRECTLY FROM BUILDING STRUCTURE



INSTALLATION

STEP 1: MOUNTING

WARNING



CRUSH HAZARD. To prevent **SERIOUS INJURY** or **DEATH**, ALWAYS mount fan directly from building structure that can withstand double the installed fan weight.

- **CAUTION:** Do not install the fan from a single structure such as a perlin, truss, I-beam or bar joist.
- For any questions or concerns regarding the building structure, consult a structural engineer.
- Ensure the attachment point can support two times the weight of the fan and maximum torque of 75ft lbs. A structural engineer should verify the structure prior to fan installation.

RIGID MOUNT OVERVIEW

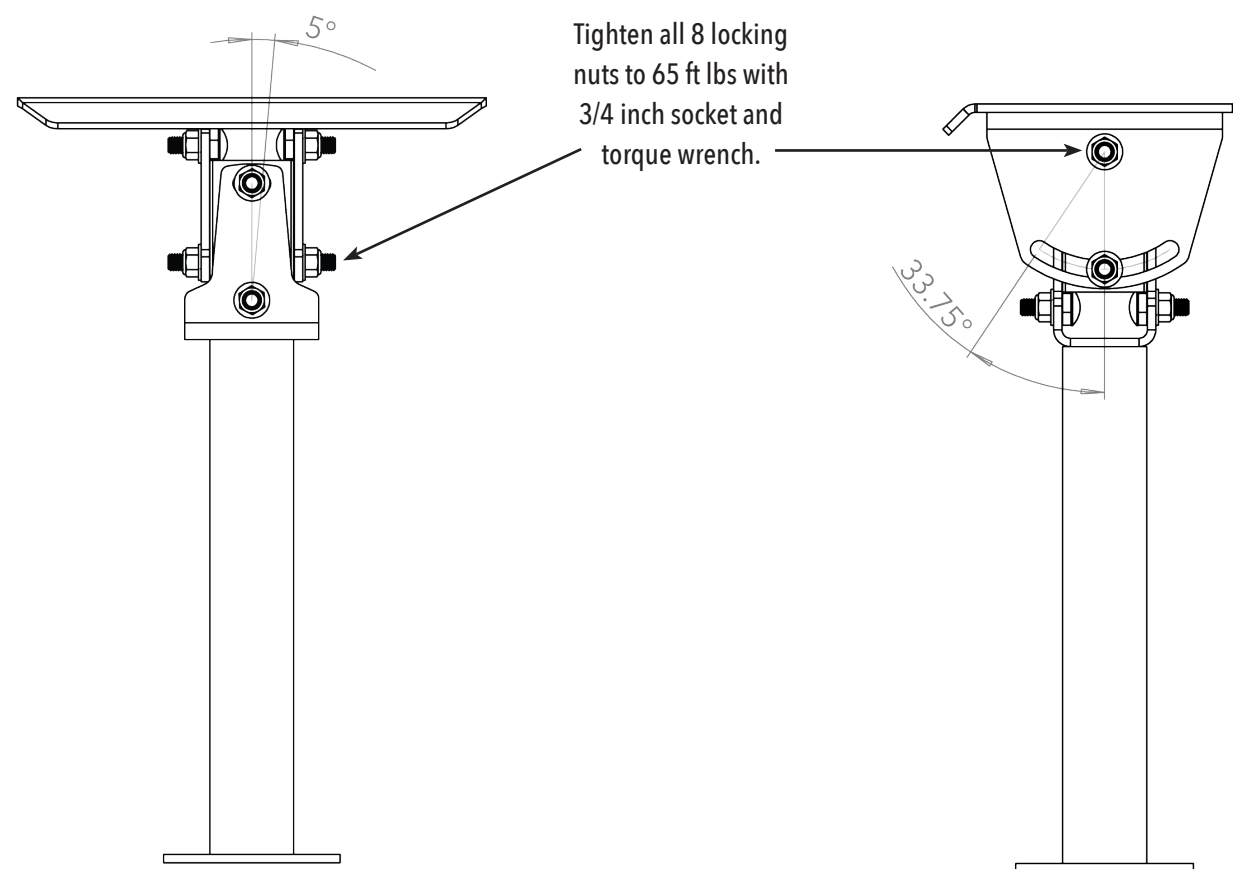

5 degrees of adjustment to accommodate an unlevel beam.

33.75 degrees of adjustment to accommodate 8/12 roof pitch.



INSTALLATION

STEP 2: RETENTION SYSTEM

WARNING



CRUSH HAZARD. To prevent **SERIOUS INJURY** or **DEATH**, ALWAYS mount fan directly from building structure that can withstand double the installed fan weight.

A

Wrap retention cable around building structure that can withstand double the installed fan weight.

B

Secure remaining cable to itself with cable clamps.

NOTE

Leave approximately 3" of slack in the wire and the cable at the top of the downrod opening.

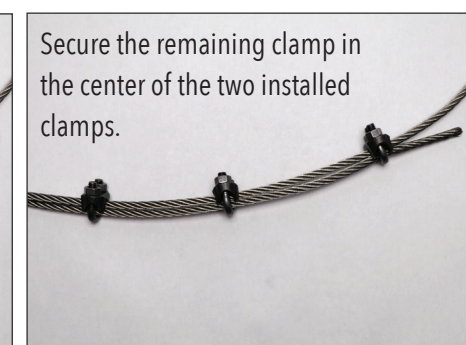
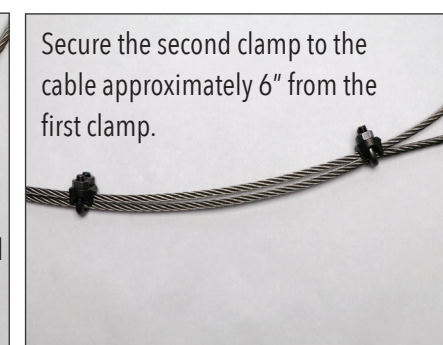
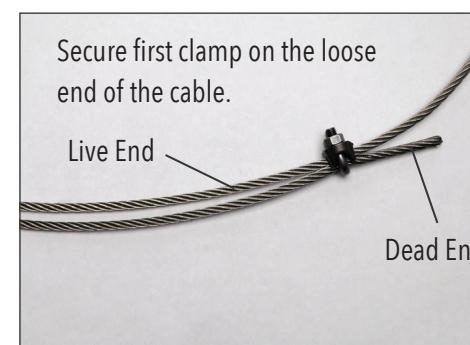
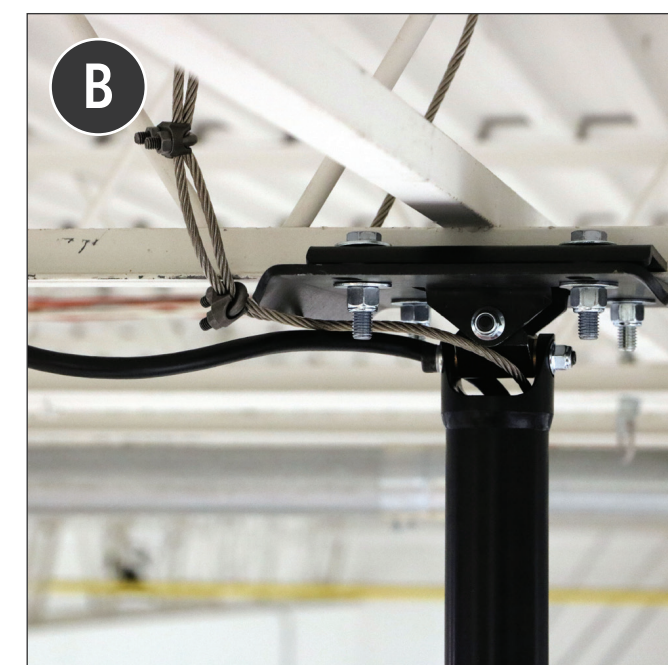
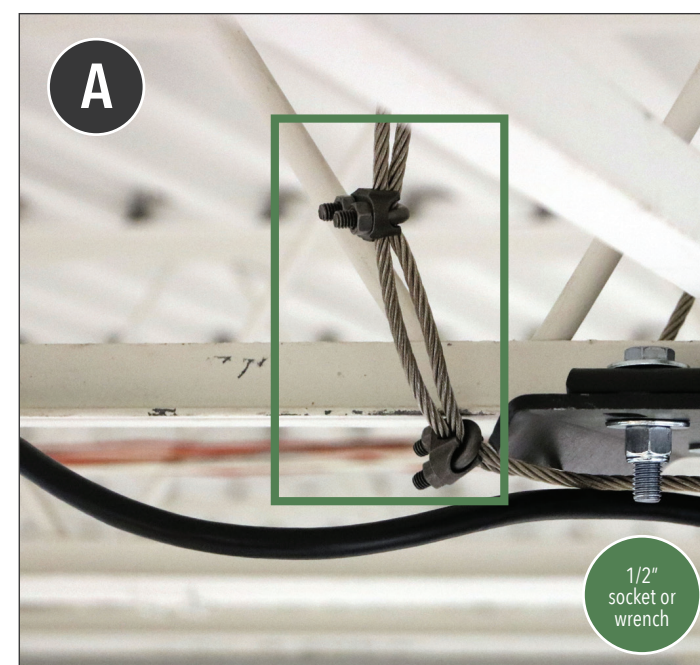

Orient the u-bolt on the "dead" end of the Retention Cable and the damp on the "live" portion of the retention cable. If done incorrectly, the U-bolt could crush the wire when tightened and can reduce the strength of the wire.



INSTALLATION

STEP 3: MOTOR ASSEMBLY

WARNING



CRUSH HAZARD. To prevent serious injury or death, ALWAYS attach the retention cable to the fan motor and secure to the building structure on EVERY fan.

A

Insert retention link into fork and align holes.

Insert clevis pin into retention rod and secure with provided clip.

B

Align the connector from the motor with the downrod connector.

Twist the collar on the connector to complete the connection. Do not force. Connectors should slide together as they twist.

Be sure to twist until the connection locks.

Zip tie the motor cable to the safety cable to reduce the opportunity to pinch the cable

C

Lift motor up to downrod while pushing cables into downrod.

Feed the press studs through downrod flange.

Secure with nylon lock nuts. (Pull excess wire and cable through top of downrod.)

NOTE

Leave approximately 3" of slack in the wire and the cable at the top of the downrod opening.



NOTE

Be sure not to pinch the motor cable when raising the downrod into place. A zip tie is recommended to secure the motor cable to the safety cable to ensure that pinching does not occur.

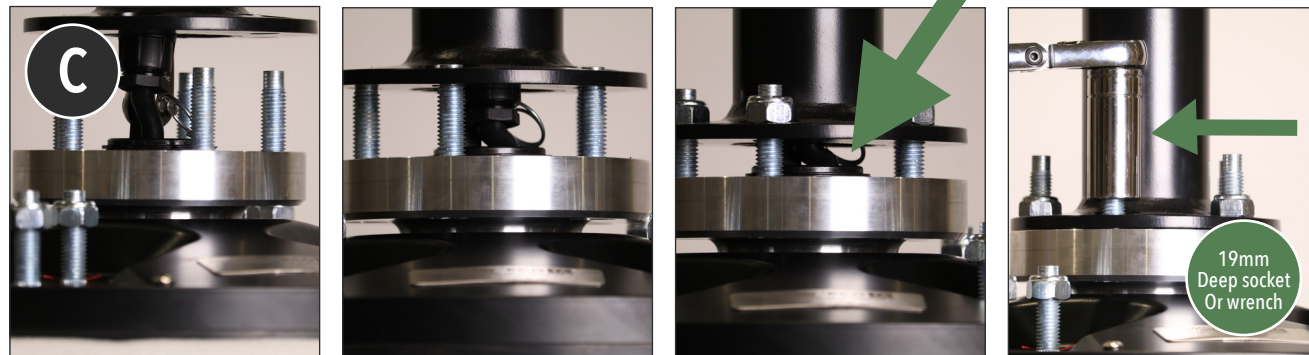

19mm Deep socket Or wrench



INSTALLATION

STEP 4: VARIABLE FREQUENCY DRIVE (VFD) CONTROL PANEL

A

The VFD control panel should be mounted directly above the fan and downrod.

B

Position the VFD control panel with plug connectors facing down.

If using uni-strut attached to the building structure, secure industrial control panel with four 1/4"-20 fasteners, one in each corner of the panel.

C

Connect the VFD cable from fan to the industrial control panel. Orient the cable to the connection so it engages slightly. Twist to lock in place. Secure excess cable to mounting location.

D

Connect the communication cable (Cat 5) to one of the COMM terminals and run cable down to the control location.

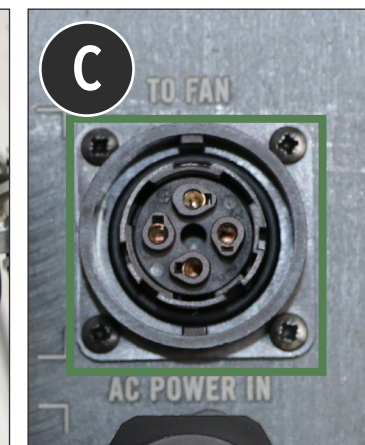
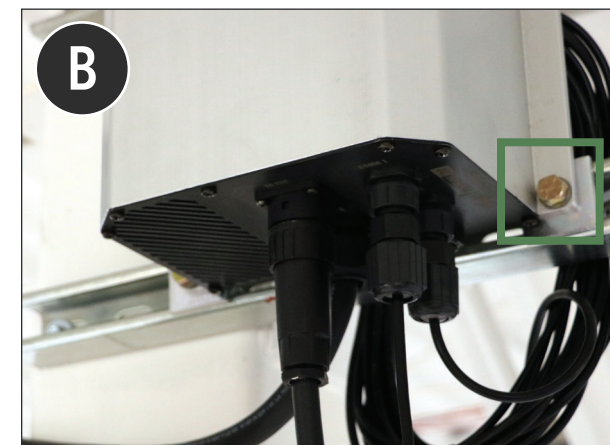

NOTE

Twist Lock will act as a disconnect.

CAUTION: DO NOT ENERGIZE CIRCUIT UNTIL MECHANICAL INSTALLATION IS COMPLETE

NOTE

Align male connector with female receptacle. Do not force connector into receptacle.

NOTE

USE COMM 2 FOR MULTIFAN INSTALL



INSTALLATION

STEP 5: GUY WIRES TITAN & ECO ONLY

WARNING



- Attach guy wire to building structure while maintaining a 45° angle between the ceiling and the guy wire.
- Do not wrap guy wires around the building structure. The guys wires could fray if in contact with the building structure.

A

Attach beam clamps to structure. Clip 15' guy wire end to beam clamp.

B

Make sure that guy wires are evenly spaced 90 degrees apart. Do not place guy wires on the same plane as the downrod, or another guy wire.

C

Feed one end of the 15' guy wire through the Gripple.

D

Clip end of the 2' guy wire to the eyebolt of the turnbuckle.

E

Feed the opposite end of the 2' guy wire through the same Gripple as the 15' guywire from step B.

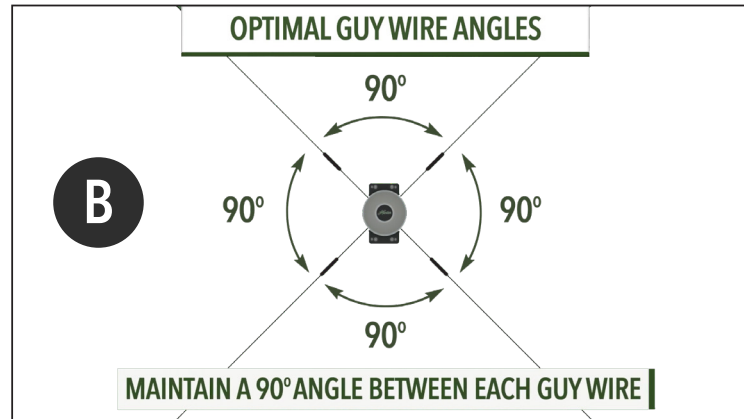
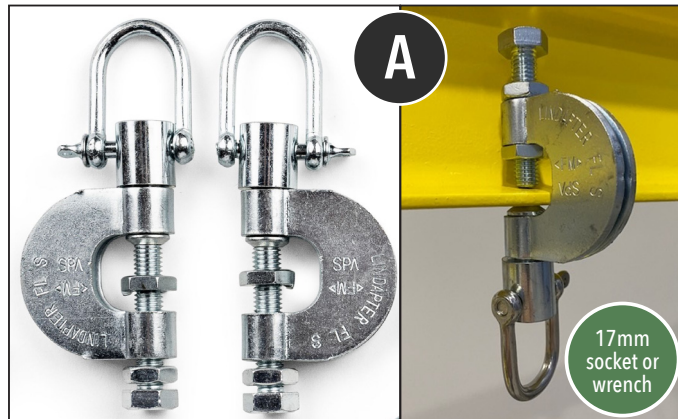

NOTE

Make sure the guy wires do not interfere with cables or other obstructions.

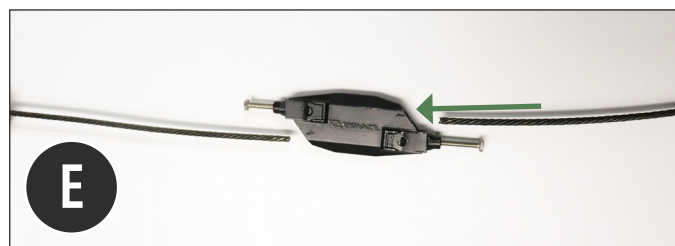
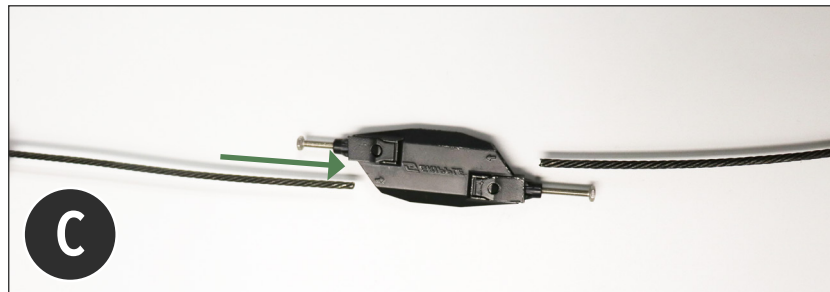

INSTALLATION

STEP 5: GUY WIRES TITAN & ECO ONLY

WARNING



- Attach guy wire to building structure while maintaining a 45° angle between the ceiling and the guy wire.
- Do not wrap guy wires around the building structure. The guys wires could fray if in contact with the building structure.

F

Feed guy wires through disc to hold in place during turnbuckle installation. Pull excess cable until guy wire is taut. Place level against the downrod and tighten the turnbuckles by hand in a crisscross pattern, periodically checking to ensure the downrod is plumb and the fan is level.

G & H

Tighten bolts on Gripples, and then tighten the set screws on the turnbuckles.

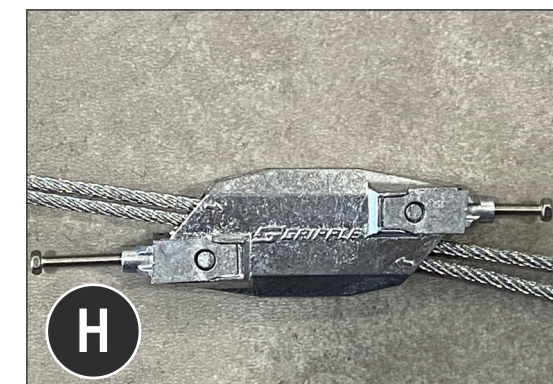
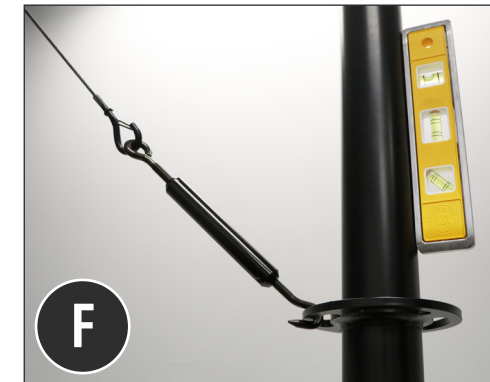



INSTALLATION

STEP 6: ECO & XP BLADE INSTALL

A

To install blade, insert the press studs through the holes in the blade holder.

Remember to install with the numbers facing up.

B

Start the nylon lock nuts onto the press studs to hold in place.

C

Tighten the nylon locknuts on the press studs using the 19mm wrench or socket.

D

Repeat steps A-C for each of the remaining blades.



NOTE

The blade is marked with a number to signify which size fan with which it goes. Make sure you match the correct blade size with the correct motor size.

19mm Deep socket or wrench



INSTALLATION

STEP 6: TITAN BLADE INSTALL

A

Line up the pin on the blade holder with the opening on the hub and insert until pin clicks into place.

B

Install the supplied patch bolt and tighten until it fully seats against the retention pin.

C

Use a torque wrench to tighten the two set screws to 20 ft. lbs (240 in. lbs.) Alternate between the two set screws 2-3 times to ensure proper torque.

D

Repeat steps A-C for each of the four remaining blades.

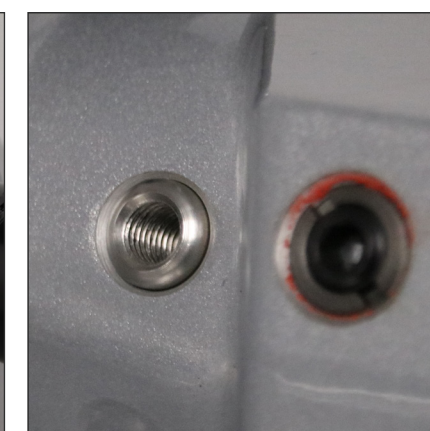
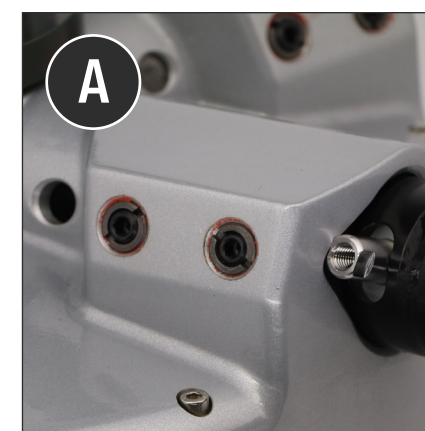

NOTE

The blade end is marked with a number to signify which size fan it goes with. Make sure you match the correct blade size with the correct motor size.

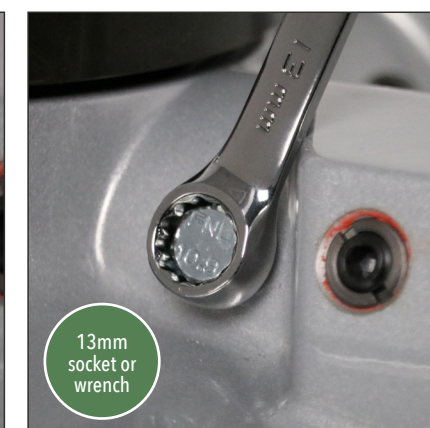
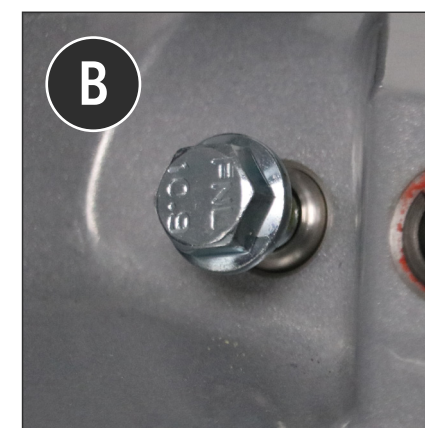

One 5mm Allen head socket will be included in every Titan order.



REFERENCE

TITAN ELECTRICAL

Electrical Plug Requirements

Voltage	Phase	Plug (included)	Receptacle
200-240V	Single	HBL2321	L6-20R
200-240V	Three	HBL2421	L15-20R
380-480V	Three	HBL2431	L16-20R

HBL2321



HBL2421



HBL2431



Do not use extension cord with fan.
Do not remove covers while power is on.
Do not use improper voltage source.



REFERENCE

ECO ELECTRICAL

Electrical Plug Requirements

Voltage	Phase	Plug (included)	Receptacle
200-240V	Single	HBL2321	L6-20R
200-240V	Three	HBL2421	L15-20R
380-480V	Three	HBL2431	L16-20R

HBL2321



HBL2421



HBL2431



Do not use extension cord with fan.
Do not remove covers while power is on.
Do not use improper voltage source.

TITAN AMP DRAW

FAN DIAMETER	220V/1P	RECOMMENDED BREAKER SIZE	220V/3P	RECOMMENDED BREAKER SIZE	480V/3P	RECOMMENDED BREAKER SIZE
24 ft	6.5A	10A	3.5A	10A	3.0A	5A
20 ft	6.5A	10A	3.5A	10A	3.0A	5A
18 ft	6.5A	10A	3.5A	10A	3.0A	5A
16 ft	6.5A	10A	3.5A	5A	3.0A	5A
14 ft	6.5A	10A	3.5A	5A	3.0A	5A

ECO MAX AMP DRAW

FAN DIAMETER	220V/1P	RECOMMENDED BREAKER SIZE	220V/3P	RECOMMENDED BREAKER SIZE	480V/3P	RECOMMENDED BREAKER SIZE
24 ft	6.5A	10A	3.5A	5A	2.0A	5A
20 ft	6.5A	10A	3.5A	5A	3.0A	5A
18 ft	6.5A	10A	3.5A	5A	3.0A	5A
16 ft	6.5A	10A	3.5A	5A	3.0A	5A
14 ft	6.5A	10A	3.5A	5A	3.0A	5A
12 ft	6.5A	10A	3.5A	5A	3.0A	5A
10 ft	6.5A	10A	3.5A	5A	3.0A	5A
8 ft	6.5A	10A	3.5A	5A	3.0A	5A



Electrical Plug Requirements

Voltage	Plug	Receptacle*
110-120V	L5-15P	L5-15R



Breaker Size Chart

XP AMP DRAW		
FAN DIAMETER	110V/1P	RECOMMENDED BREAKER SIZE
14 ft	8.3A	10A
12 ft	8.3A	10A
10 ft	8.3A	10A
8 ft	8.3A	10A
7 ft	8.3A	10A

Do not use extension cord with fan.
 Do not remove covers while power is on.
 Do not use improper voltage.

*Not included but required for installation.



All communication connections must be made with shielded CAT5e/6 cabling.

A
 In all configurations and installs of Hunter HVLS fans the Lead fan's VFD must be the labeled "Power" drive. This VFD must be connected to the HMI from the COMM 1 port directly when using the 350 or 500 Series HMI. If using 700E HMI COMM 1 must connect to the Network Switch, and then the Network Switch to the HMI.

B
 Using the COMM 2 port on the Lead Fan's VFD connect remaining fans in the network per the applicable diagram below.

C
 Follow the HMI User Manual for HMI installation and configuration set up.

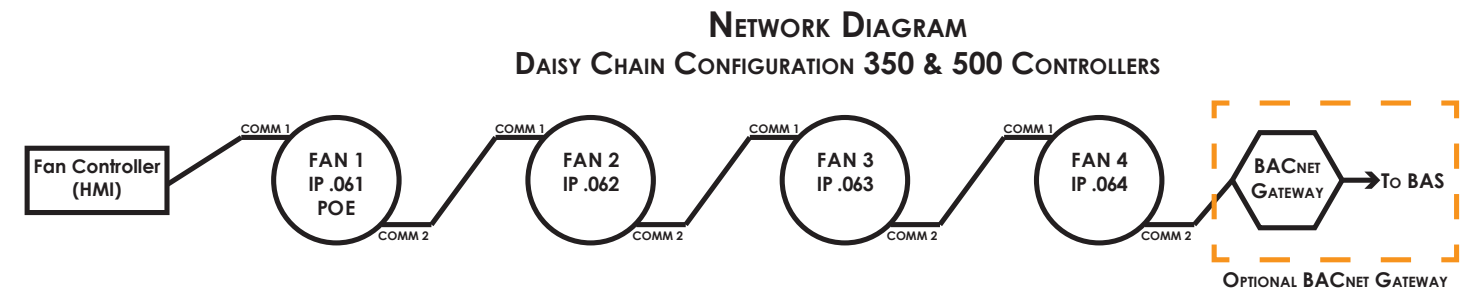

NOTE
 When connecting multiple fans to one HMI Controller (**Daisy Chaining**) use the COMM Port 2 on the lead VFD to connect the next VFD using the CAT5 cable into COMM Port 1. Repeat for each sequential fan.



REFERENCE

COMMON FAN NETWORK CONFIGURATIONS

NETWORK DIAGRAM
WITH 700E ENVIRONMENTAL CONTROL
ZONE 1 & ZONE 2 ARE LESS THAN 100 METERS APART

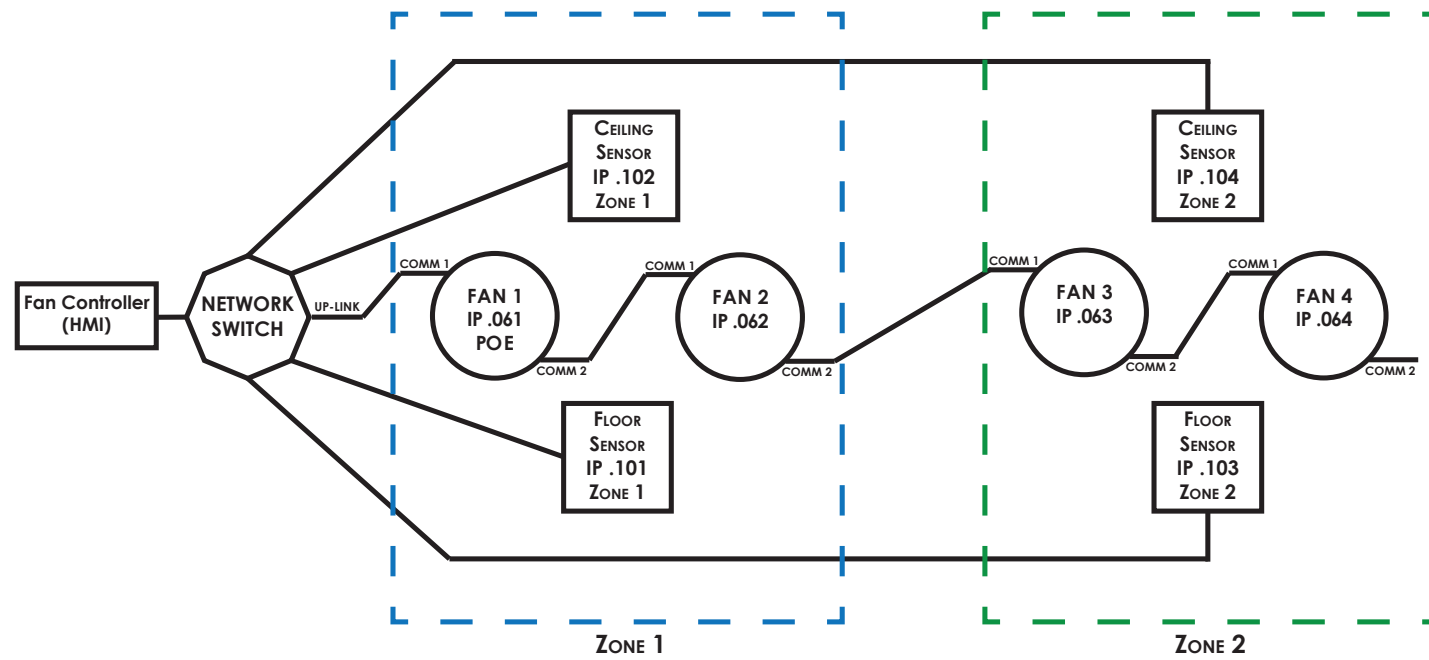

REFERENCE

COMMON FAN NETWORK CONFIGURATIONS

NETWORK DIAGRAM
WITH 700E ENVIRONMENTAL CONTROL
ZONE 1 & ZONE 2 ARE MORE THAN 100 METERS APART

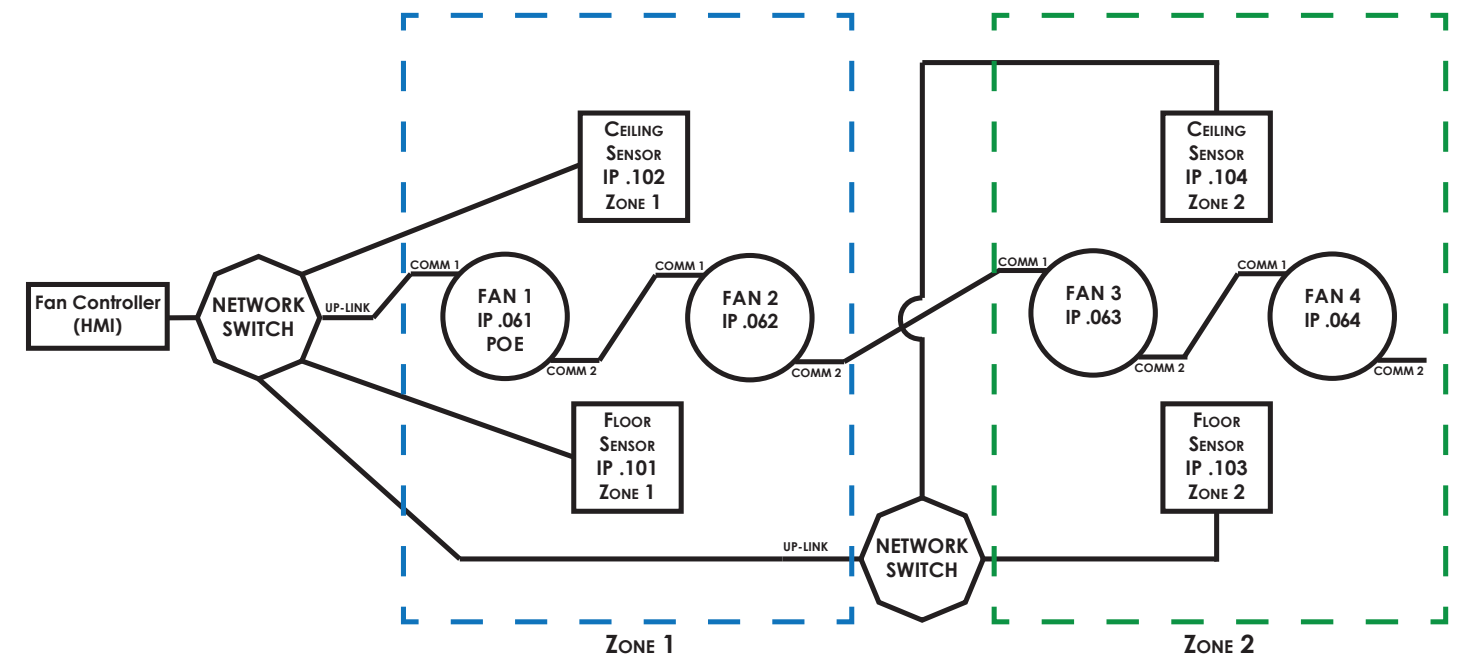



REFERENCE

COMMON FAN NETWORK CONFIGURATIONS

POWERED VFD (LEAD FAN VFD. MUST CONNECT TO HMI CONTROLLER)



NON-POWERED VFD (CAN NOT BE LEAD FAN VFD. MUST NOT CONNECT TO HMI CONTROLLER)



REFERENCE

FIRE PANEL (FIELD WIRING)

DRY CONTACTS: NORMALLY CLOSED

- On the Terminal Strip mounted to the outside of the VFD enclosure a Jumper will be in place on terminals "S" and "C". Remove the Jumper from terminals "S" and "C".
- Connect the wires coming from the Fire Panel to terminals "S" and "C".

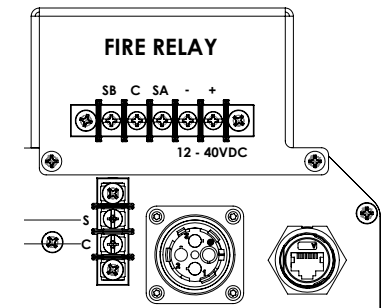

NORMALLY ENERGIZED

- On the Terminal Strip mounted to the outside of the VFD enclosure a Jumper will be in place on terminals "S" and "C". Remove the Jumper from terminals "S" and "C".
- Connect a wire from terminal "S" to "SA" on the Fire Relay Terminal Strip.
- Connect a wire from terminal "C" to "C" on the Fire Relay Terminal Strip.
- Apply 12-40VDC from Fire Panel to Fire Relay Input. Relay has a 20mA draw.

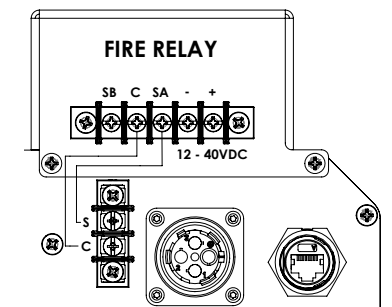

NORMALLY UNENERGIZED

- On the Terminal Strip mounted to the outside of the VFD enclosure a Jumper will be in place on terminals "S" and "C". Remove the Jumper from terminals "S" and "C".
- Connect a wire from terminal "S" to "SB" on the Fire Relay Terminal Strip
- Connect a wire from terminal "C" to "C" on the Fire Relay Terminal Strip.
- Apply 12-40VDC from Fire Panel to Fire Relay Input. Relay has a 20mA draw.

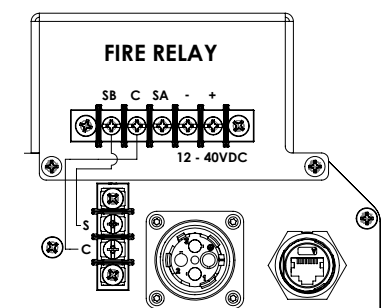



REFERENCE

FIRE PANEL (FIELD WIRING)

Fire Relay arrangement for multiple fans (30 Fan Maximum)

NORMALLY ENERGIZED/UNENERGIZED

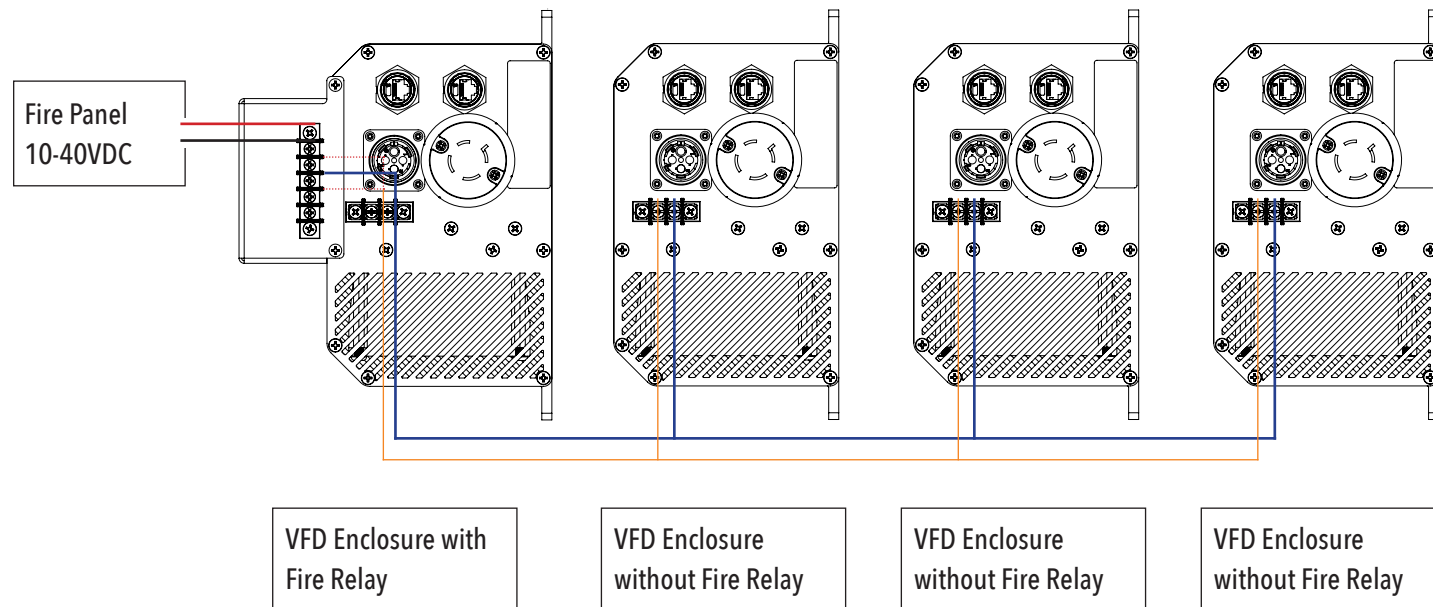

DRY CONTACTS: NORMALLY CLOSED

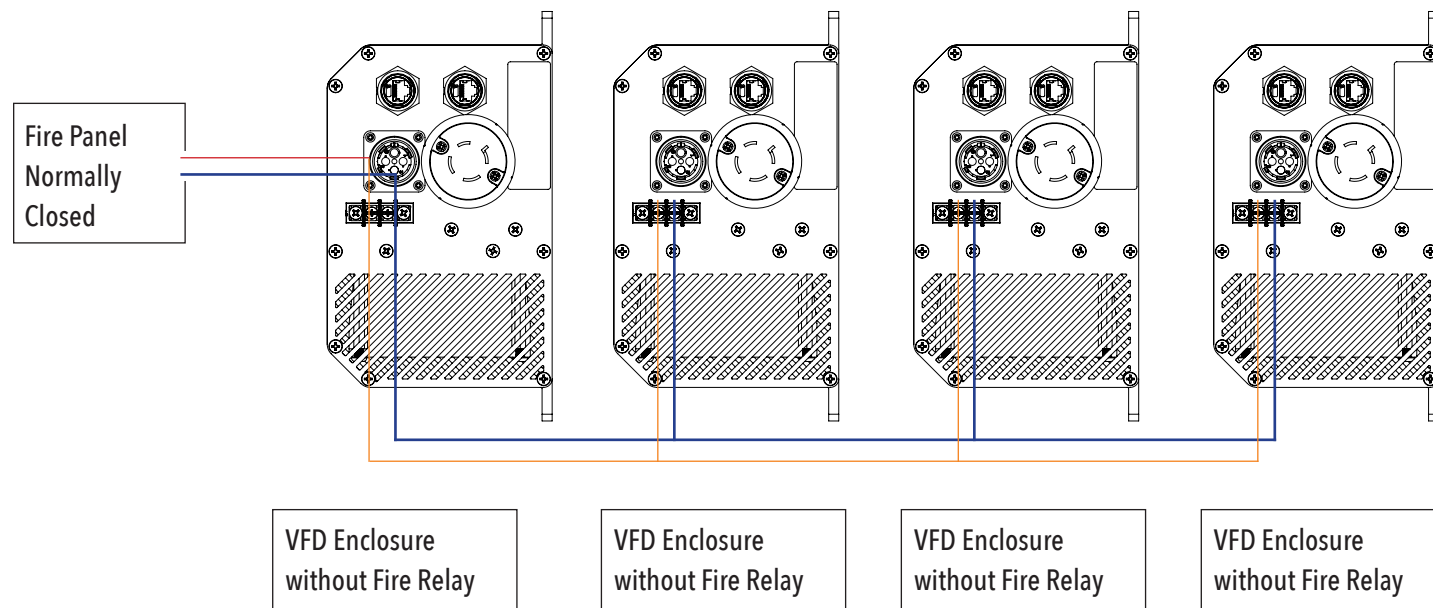

REFERENCE

LINE FILTER (INTERNATIONAL ONLY)



FILTER INSTALLATION GUIDE

Thank you for purchasing an MTE Corporation, Radio Frequency Interference (RFI) filter. Please follow guidance for the safe operation of this device:

- Device is intended for RFI filtering via connection to the mains power line network.
- Device must be installed in accordance with local regulations and by a qualified engineer.
- Protection and performance may be impaired if used in any unspecified manner.
- Refer to the device Specifications for additional and specific product information.
- Do not exceed any product ratings or use outside the stated environmental conditions.
- Device is suitable for mains power frequencies 50-60Hz. DC is also acceptable.
- Device is suitable for 40°C unless specified, installation category II (cat III cabinet).
- Device is rated for RMS Voltage and Continuous RMS current, overload 150% 60s.
- Use EN 61010-031 probes (4mm exposed or less) when testing live voltages.
- Use appropriate RCD protection with sensitivity suitable for the application (Type B).
- Use fast acting, current-limiting fuses with maximum interrupting capacity (Type J,R,T).
- Use enclosures with restricted access and any terminals covers provided or available.
- Observe the Line, Load and Earth designations and correct phase orientation.
- Terminals marked Protective Earth (PE) must connect to the Protective Earthing System.
- Device chassis should be directly bonded to ground to ensure safety and performance.
- Device clearance; 50mm on vented sides. Non-vented sides can be placed directly against non-heat generating parts. Orientation must be horizontal or vertical book.
- Unless otherwise stated, use the minimum typical recommended torque settings.
- Observe Safety Warnings! Hazardous Voltages, Currents and Stored Charges may exist during and after supply isolation!

Recommended Maximum Torque

RFI Filter	Nm	in lb
RF3-0006-4	0.8	7
RF3-0006-6		
RF3-0010-4		
RF3-0010-6	2	17-7
RF3-0018-4		
RF3-0018-6		
RF3-0025-4	1.9	16.8
RF3-0025-6		
RF3-0033-4		
RF3-0033-6	4.5	39.8
RF3-0050-4		
RF3-0050-6		
RF3-0070-4	8	70.5
RF3-0070-6		
RF3-0090-4		
RF3-0090-6	12	106
RF3-0130-4		
RF3-0130-6		
RF3-0150-4	25/31	221/274
RF3-0150-6		
RF3-0330-4 (M10) Brass/Steel		
RF3-0330-6 (M10) Brass/Steel		

N83 W13330 Leon Road, Menomonee Falls, WI 53051
USA Phone: 262-253-8200 Fax: 262-253-8222 Email: www.mtecorp.com

Form: RF-IG-E April 2019 Rev 002



Type RF EMI/RFI Filters – Additional Technical Information

In addition to the Product Selection brochure, this Application Note contains useful information on how to properly connect an EMI/RFI filter, understand the current ratings, and parallel connections for higher ratings when necessary.

Type RF EMI/RFI filters are built with Touch Safe Construction.

- In compliance with international safety standards, and in conformance with the CE Low Voltage Directive, these filters are supplied as standard with touch safe terminations on all units rated 150 Amps and below.
- Units rated higher than 150 Amps provide tab terminals for customer addition of wiring devices.

Connection of the Type RF EMI/RFI filters is intended for use at the input side of a variable speed drive or inverter ONLY.

- DO NOT use these filters on the output (load side) of an inverter or drive.
- Good wiring practices will minimize RFI problems, including:
 - o Route all conductors as close to the panel as possible.
 - o Physically separate the filter input and output conductors.
 - o Keep drive input and output leads separated.
 - o Always keep power and control wiring separated.
 - o Use shielded wiring where possible.
 - o Use single point grounding (connect system ground to filter).

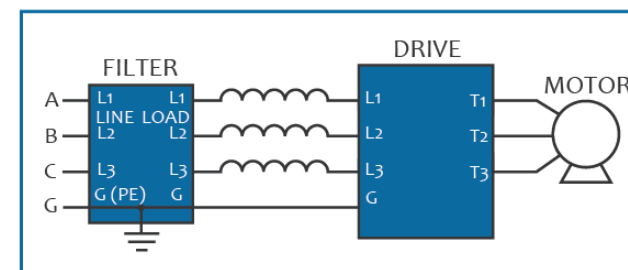

- Connect the incoming power conductors to the "Line" side terminals of the filter.
- Connect the "Load" side terminals to the line reactor or drive input terminals.
- The ground termination "G" may also be designated by "PE" or "N".
- Keep all wiring as close as possible to the grounded panel (ground plane).

Type RF EMI/RFI filters are rated in True RMS (trms) amperes.

- Harmonic current distortion will increase the trms current of a system above the fundamental - current (typically motor FLA) of the connected loads.
- Line reactors (3% or 5% impedance) are useful in reducing harmonic current distortion and the trms current.
- If minimum 3% impedance line reactors are included in the installation, then the trms amperes will be lower and the filter can be sized for the reduced load current.
- If the trms amperes of the load to be connected to the filter are known, then select the filter directly from the RMS amperes selection tables.
- If the trms amperes are unknown, you can select the filters based on the horsepower (or kW) rating of the load to be connected.
- Determine if a reactor (minimum 3% impedance) will be used in addition to the Type RF filter and select accordingly.

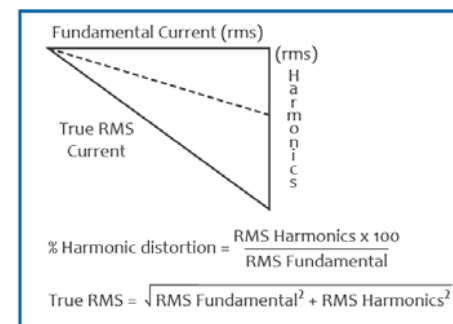

Parallel connection to achieve higher current ratings is possible with the Type RF EMI/RFI filters provided that identical models are used and the connection allows each individual filter to share current equality.

- Two separate terminal blocks will make this easier.
- Derate each filter by 10% when connecting in a parallel configuration, and always follow the NEC or local electrical codes.
- Make ground connections first.
- For each filter to be parallel connected, precut three leads of equal wire type and gauge to the same exact length. Connect the filter input terminals L1, L2, and L3 to the respective terminal on a separate terminal block. Repeat this procedure for the output terminals.
- For higher current single phase applications use an appropriately rate three phase filter. Connect the outer terminals of the three phase filter to the single phase connections.

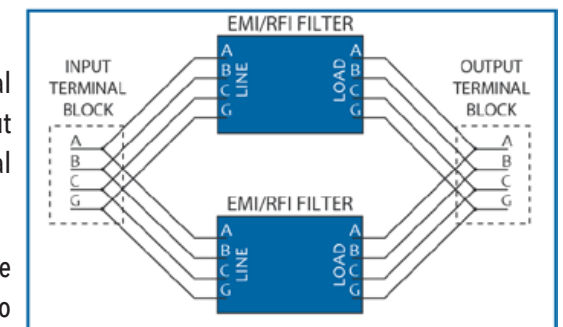

Single phase applications are also available.

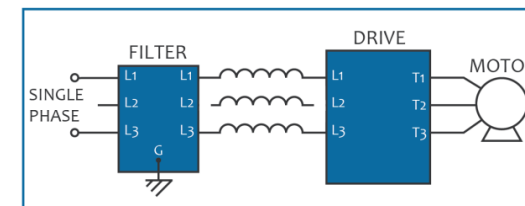



WARNING **ELECTRIC SHOCK HAZARD**

TO PREVENT SERIOUS INJURY OR DEATH:

- **BEFORE** performing maintenance or service, **ALWAYS** disconnect the power by turning off the circuit breaker or breakers to the fan locations and confirm Lockout/Tagout procedures are in place.
- If you cannot lock the circuit breakers in the off position, securely fasten a prominent warning device, such as a tag, to the electrical panel.
- Do not remove covers while power is on.

Blade Cleaning

Depending on the commercial application, dust or other particulates can build up on the fan blades over time. At least every 12 months, a maintenance person or skilled trade professional, who has experience using a lift, should clean the blades using a rag or sponge and hot water or regular cleaning solutions. DO NOT use chlorine or any chemicals containing chlorine or the blades may be damaged.

Retention System Check

Each fan is installed with a retention system. Every 12 months, check that the retention cable is properly attached to the building structure. Inspect the visible portions of the retention cable for damage, including fraying.

The retention cable is an important part of the safety system and protects users in the unlikely event of a catastrophic situation. It is critical for fan owners to ensure that it is intact and properly secured.

Replacement Parts

Please call 1-844-593-FANS (3267) for replacement parts.

Service

If the fan does not operate properly using the procedures in this manual, follow Lock-Out, Tag-Out procedures for your facility and lockout all power to the unit and contact our Technical Department for further assistance at 1-844-593-FANS (3267).



Symptom	Possible Solution
FAN WILL NOT START	<ul style="list-style-type: none"> • Verify that the fan's circuit breaker has power and that it is on. • Verify that the VFD's receptacle has power and that the VFD is plugged in. • Check for secured plug connections. Each connection should be checked to ensure they are fully engaged. • Inspect for loose wiring connections. Each termination should be checked to be sure they are firmly tightened.
IF THE ABOVE IS VERIFIED AS WITHIN SPECIFICATION	<ul style="list-style-type: none"> • Cycle the power to the VFD by flipping the circuit breaker off for a minimum of three minutes. Flip the circuit breaker back on and check the fan's operation.
MOTOR IS PULLING EXCESSIVELY HIGH AMPS	<ul style="list-style-type: none"> • Make sure the VFD voltage is a match for the supply voltage. • Make sure that correctly sized fan blades have been installed.
FAN IS "SWINGING" AS IT RUNS	<ul style="list-style-type: none"> • Check for correct fan blade installation. Be sure that all blades are the same size and that all blades have been properly installed and tightened. • Ensure all guy wires are tensioned properly and that the downrod is plumb. • Check for improper incoming air discharge. Make sure that no discharge is blowing directly on the fan.
A FAN BLADE APPEARS TO BE 'SAGGING'	<ul style="list-style-type: none"> • Make sure that the 'sagging' blade has been properly tightened.

For situations beyond the scope of this guide, please call our Technical Service Department at 1-844-593-FANS (3267).



Hunter

180 Threet Industrial Street
Smyrna, TN 13167

1-844-591-FANS (3267)
TECHNICAL DEPARTMENT: 1-844-593-FANS (3267)

INDUSTRIALFANS.HUNTERFAN.COM/

©2022 Hunter Fan Company. All rights reserved. | Rev 04/27/2022

